

FCP 4100 – 8100 INT

/ Inside linear welding system

/ TIG / ArcTIG / Plasma / CMT



Linear seam welders of the FCP 4100 - 8100 INT series are special for inside welding of cylindrical parts with big diameters e.g. tanks & vessels.

FEATURES

- / Welding of tanks / vessels with a length up to 8000 mm (depending on model variant)
- / Welding processes: TIG, ArcTIG, Plasma, CMT
- / Welding carriage configured with motorized horizontal and vertical slides (OSC / AVC), laser pointer for centering support, wire feeder on carriage and optional ArcView camera
- / Pneumatic clamping system with clamping plates manufactured in special copper alloy
- / Hydraulic adjustable supporting bar with rollers, fully adjustable to the parts diameter
- / Hydraulic height-adjustable lower beam with water-cooled copper bar
- / Automatic mandrel latch (hydraulic)
- / HMI-T10 system controller with 10" touch screen and remote control guarantees intuitive operation, real-time welding process visualization and welding data documentation
- / Cooling unit for copper bar and torch



/ Supporting bar with rollers



/ Height adjustable lower beam



/ Adjustable clamping plates

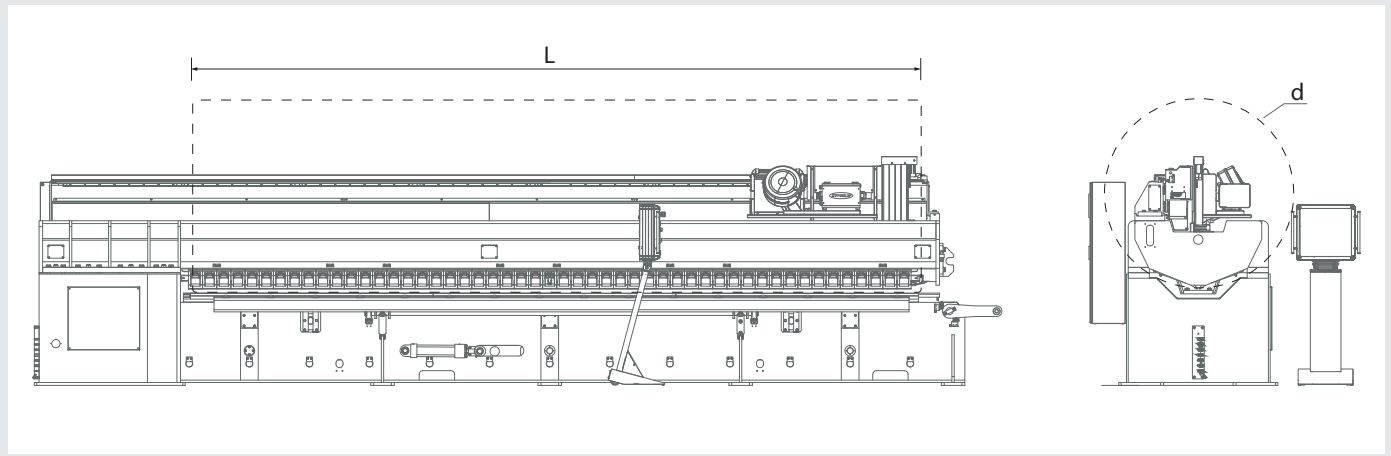

TECHNICAL DATA

	FCP 4100 INT	FCP 5100 INT	FCP 6100 INT	FCP 7100 INT	FCP 8100 INT
Max. parts length / weldable length (L)	4000 mm (157.48 inch)	5000 mm (196.85 inch)	6000 mm (236.22 inch)	7000 mm (275.59 inch)	8000 mm (314.96 inch)
Min. parts inner diameter (d)	1250 mm (49.21 inch)	1250 mm (49.21 inch)	1250 mm (49.21 inch)	1500 mm (59.05 inch)	1500 mm (59.05 inch)
Material thickness	2 - 10 mm (0.07 - 0.39 inch)	2 - 10 mm (0.07 - 0.39 inch)	2 - 10 mm (0.07 - 0.39 inch)	2 - 10 mm (0.07 - 0.39 inch)	2 - 10 mm (0.07 - 0.39 inch)
Power supply	3x 400 V, 50/60 Hz	3x 400 V, 50/60 Hz	3x 400 V, 50/60 Hz	3x 400 V, 50/60 Hz	3x 400 V, 50/60 Hz

/ Perfect Welding / Solar Energy / Perfect Charging

THREE BUSINESS UNITS, ONE GOAL: TO SET THE STANDARD THROUGH TECHNOLOGICAL ADVANCEMENT.

What began in 1945 as a one-man operation now sets technological standards in the fields of welding technology, photovoltaics and battery charging. Today, the company has around 4,550 employees worldwide and 1,241 patents for product development show the innovative spirit within the company. Sustainable development means for us to implement environmentally relevant and social aspects equally with economic factors. Our goal has remained constant throughout: to be the innovation leader.

Further information about all Fronius products and our global sales partners and representatives can be found at www.fronius.com

v09 May 2018 EN

Fronius Schweiz AG
 Obergletterstrasse 11
 8153 Rümlang
 Schweiz
 Telefon 0848 FRONIUS (37 66 487)
 Gratisfax 0800 FRONIUS (37 66 487)
sales.switzerland@fronius.com
www.fronius.ch

Fronius Deutschland GmbH
 Am Stockgraben 3
 36119 Neuhof-Dorfborn bei Fulda
 Deutschland
 Telefon +49 6655 916 94-0
 Telefax +49 6655 916 94-30
sales.germany@fronius.com
www.fronius.de

Fronius International GmbH
Vertrieb Österreich:
 Froniusplatz 1
 4600 Wels
 Österreich
 Telefon +43 7242 241-0
 Telefax +43 7242 241-953490
sales.austria@fronius.com
www.fronius.at

Fronius International GmbH
 Froniusplatz 1
 4600 Wels
 Österreich
 Telefon +43 7242 241-0
 Telefax +43 7242 241-953940
sales@fronius.com
www.fronius.com